



15

Netter Vacuum Fixing Devices for Vibrators Series VAC



- Quick mounting without bolting or welding
- Strong connection due to high vacuum
- Can also be used on curved or uneven surfaces
- Optional air economizer
- ATEX conform and stainless steel versions available
- Customized versions possible



VAC 10 with NCT 4



VAC 15 with PKL 150 ST



VAC 30 with NTS 50/04



Netter Vacuum Fixing Devices for Pneumatic Vibrators Series VAC

Type	Air consumption without vibration [l/min]		Weight [kg]	Minimum diameter for round containers [mm]	Suitable vibrator
	4 bar	6 bar			
VAC 8 + HG 10 N	40	60	0,95	110	NCB 1-2, NCT 1-2; NTK 8 AL - 18 AL, NTP 25 B**; NTS 120-180 HF+NF*
VAC 8 + HG 10 S	20	22	1,20		
VAC 10+HG 10 N	40	60	1,05	110	NCB 1-3, NCR 3, NCT 3-4, NTK 15X, NTK 18 AL, NTP 25 B**; NTS 180-250 HF+NF*, PKL 125**
VAC 10+HG 10 S	20	22	1,30		
VAC 11+HG 10 N	40	60	1,25	110	NCB 3-5, NCR 10, NCT 5-10, NTK 18 AL, NTS 180-250 HF+NF, PKL 135**
VAC 11+HG 10 S	20	22	1,50		
VAC 12+HG 15 N	60	122	2,85	350	NCB 10-20, NCR 22, NCT 15-29, NTP 32 B**, PKL 135**+150**, PKL 170*, NTK 25 AL, NTS 350 HF+NF, NTS 100/01-50/01**
VAC 12+HG 15 S	29	36	3,20		
VAC 15+HG 15 N	110	170	3,40	650	NCB 10-70, NCR 22-57*, NCT 15-108*, NTP 32 B-48 B*; PKL 150, NTK 18 AL, NTK 25, NTS 75/01-70/02*, NTS 250-350 HF+NF
VAC 15+HG 15 S	41	52	3,75		
VAC 20+HG 15 N	110	170	7,25	850	NCR 57, NCT 55-108, NTP 32 B-48 B, NTS 70/02-50/04*, PKL 170, PKL 220
VAC 20+HG 15 S	41	52	7,60		
VAC 30+HG 30 N	110	170	11,50	1.500	NCR 120, NCT 250, NTS 50/04, NTS 50/08*, NVG 49/55/61, NVG 82/84*, PKL 200/5
VAC 30+HG 30 S	49	60	12,00		
VAC 40+HG 40 N	220	340	20,00	1.500	NTS 50/08*, NTS 50/10*

The technical data are comparative values and can vary depending on the application. Additional data available upon request.

*Depending on application, please consult Netter. **Adapter plate necessary, please include in order!

Type	A [mm]	B [mm]	C [mm]	D [mm]	E [mm]	F [mm]	G [mm]	Type	A [mm]	B [mm]	C [mm]	D [mm]	E [mm]	F [mm]	G [mm]
VAC 8	20	30	150	53	33	55	190	VAC 15	50	-	350	95	100	150	-
VAC 10	22	40	200	53	31	55	245	VAC 20	70	-	440	115	150	200	-
VAC 11	19	40	300	53	31	55	330	VAC 30	70	30	398	340	428	370	-
VAC 12	25	60	300	60	72	100	330	VAC 40	60	25	428	375	425	-	-

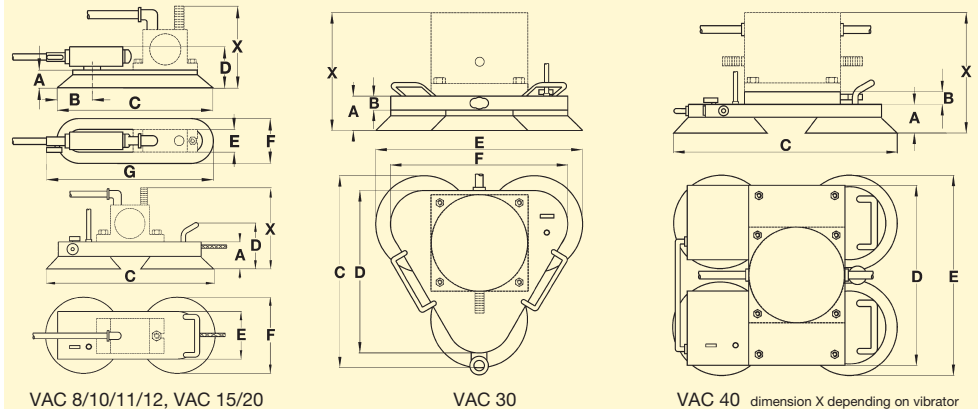

Mobile use on stainless steel container

Applications

The vacuum fixing devices series VAC are designed to allow quick attachment of vibrators to smooth or, under circumstances, uneven and curved surfaces. A special feature of the vacuum fixing is the ease of attachment, which requires no welding or bolting.

Construction and working principle

The appropriate vibrator is screwed to the vacuum fixing and connected to the supply hose leading to the hand valve.

As soon as the vacuum fixing is connected to the compressed air supply, the unit is sucked tightly to the mounting surface, thus ensuring a strong connection between the vibrator and the surface.

The air economizer "S" creates a reduced vacuum, which is sufficient to clamp the vibrator when it is not running and which reduces the air consumption by over 30%.

ATEX conform vacuum fixings series VAC and units with a stainless steel plate are available.

When the vibrator starts, the fixing device automatically produces the full vacuum.

Permissible operating conditions

Drive medium:

Compressed air or nitrogen (filter ≤ 5µm)

Operating pressure:

2 bar to 6 bar

Ambient temperature:

-10°C to 60°C

NetterVibration offers the accessories required for the mounting, installation and control of vibrators and interval impactors.

Netter provides solutions.

Consult our experienced application technicians.

Netter GmbH

Germany

Fritz-Ullmann-Str. 9
55252 Mainz-Kastel
Tel. +49 6134 2901-0
Fax +49 6134 2901-33

United Kingdom

2 Sandpiper Close
Station Road
Hednesford, WS12 4RN
Tel. +44 1543 424990
Fax +44 1543 423196

Switzerland

Erlenweg 4
4310 Rheinfelden
Tel. +41 61 8316200
Fax +41 61 8311291

www.NetterVibration.com
info@NetterVibration.com